

# 8

# LADDER HEIGHT ACCESS

Stockmaster Ladders Height Access----- 90

Monstar Ladders ----- 93

Bailey Modular Access System ----- 96

Platform Stepladder Safety Gates ----- 98

Aluminum Ladders ----- 98

Fibreglass Ladders ----- 99

Safety Step Stools ----- 100

Work Cages & Platform ----- 102

Height Safety Kits & Accessories ----- 102



### Work Platform - Stockmaster Mobile Navigator

Stockmaster Navigator is a very safe and easy to use mobile work platform. It features a Move, Steer and Brake control which eliminates the need for springs, folding steps, wheel brakes and other devices.

Move up to StockMaster **Navigator Pro** and you are protected against accidentally stepping off the front of the platform. With the fully automatic Auto-Gate your hands are free to carry an item and still maintain a safe grip as you enter or leave the work-space. And with Navigator Pro you also have Rota-Gate which provides a gate-way at the side of the platform creating easy access for stock-picking, inspection and many other tasks.

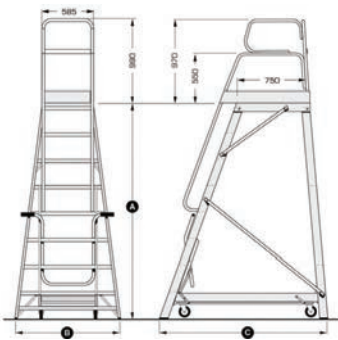

Navigator PRO with Auto-Gate and Rota-Gate

Code	Platform Height mm	Working Range mm	A mm	B mm	C mm
CU SM-N4	1145	1400 - 2800	1145	755	1295
CU SM-N5	1435	1700 - 3100	1435	795	1425
CU SM-N6	1720	2000 - 3400	1720	835	1555
CU SM-N7	2005	2300 - 3700	2005	875	1685
CU SM-N8	2295	2500 - 3900	2295	915	1815
CU SM-N9	2580	2800 - 4200	2580	955	1945
CU SM-N10	2865	3100 - 4500	2865	995	2075
CU SM-N11	3155	3400 - 4800	3155	1035	2205
CU SM-N12	3440	3700 - 5100	3440	1075	2335
CU SM-N13	3725	4000 - 5400	3725	1115	2465
CU SM-N14	4015	4300 - 5700	4015	1155	2595

For Navigator PRO model add a "P" to Code eg. CU SM-N4P

### Work Platform - Stockmaster Mobile Tracker

StockMaster Tracker is a very versatile and easy to use mobile work platform. With two large diameter wheels it moves easily over sealed and unsealed surfaces or slopes making it ideal for indoor and outdoor use. A single control to Steer and Brake makes it fast and easy to move around.

Move up to StockMaster **Tracker Pro** and you are protected against accidentally stepping off the front of the platform. With the fully automatic Auto-Gate your hands are free to carry an item and still maintain a safe grip as you enter or leave the work-space. And with Tracker Pro you also have Rota-Gate which provides a gate-way at the side of the platform creating easy access for stock-picking, inspection and many other tasks.

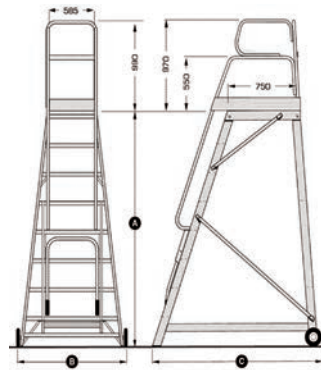

Tracker PRO with Auto-Gate and Rota-Gate

Code	Platform Height mm	Working Range mm	A mm	B mm	C mm
CU SM-T03	860	1100 - 2700	860	840	1210
CU SM-T04	1145	1400 - 3000	1145	895	1340
CU SM-T05	1435	1700 - 3300	1435	935	1470
CU SM-T06	1720	2000 - 3600	1720	975	1600
CU SM-T07	2005	2300 - 3900	2005	1015	1730
CU SM-T08	2295	2500 - 4200	2295	1055	1860
CU SM-T09	2580	2800 - 4400	2580	1095	1990
CU SM-T10	2865	3100 - 4700	2865	1135	2120
CU SM-T11	3155	3400 - 5000	3155	1175	2250
CU SM-T12	3440	3700 - 5300	3440	1215	2380
CU SM-T13	3725	4000 - 5600	3725	1255	2510
CU SM-T14	4015	4300 - 5900	4015	1295	2640

For Tracker PRO model add a "P" to Code eg. CU SM-T09P

## Step Way - Stockmaster Mobile Step-Thru

Stockmaster Step-Thru is a safe and easy to use mobile step-way and with its use the dangerous practice of climbing onto and jumping down from trucks, or the use of step ladders to access mezzanine floors and similar situations is eliminated, significantly reducing the risk of accident. With a stable stepping off platform and two side safety rails to maintain a firm hand hold, access to the work place is safe and easy. Step-Thru substantially reduces your exposure to the high cost of lost time injuries and compensation claims.

Stockmaster Step-Thru is also available with a perforated step option to provide improved grip when ascending or descending the ladder in wet weather, muddy, or other hazardous conditions.

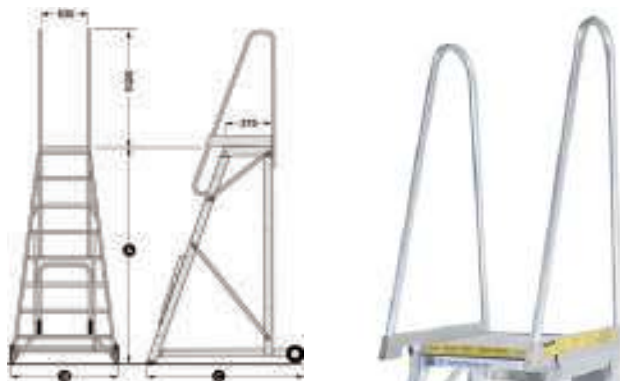

- ✓ Stockmaster Step-Thru is the right choice
- ✓ It enables a three point contact at all times
- ✓ It can be used on a wide range of surfaces
- ✓ It moves quickly and easily to where you need it
- ✓ It meets Australian, New Zealand and European Union Standards
- ✓ There's a height to suit your need

Code	Platform Height mm	Working Range mm	A mm	B mm	C mm
CU SM-ST03	860	900 - 1185	860	780	900
CU SM-ST04	1145	1185 - 1475	1145	820	1005
CU SM-ST05	1435	1475 - 1760	1435	860	1110
CU SM-ST06	1720	1760 - 2045	1720	900	1215
CU SM-ST07	2005	2045 - 2335	2005	940	1330
CU SM-ST08	2295	2335 - 2620	2295	980	1460
CU SM-ST09	2580	2620 - 2905	2580	1020	1590
CU SM-ST10	2865	2905 - 3150	2865	1060	1720

## Order Picker - Stockmaster Mobile LiftTruk

Stockmaster LIFT-TRUK is a very safe and easy to use stock picker. Items weighing up to 60 kg can be picked, lowered and transported in one action. The whole stock picking process can be safely handled by one person removing the need for a second person to pass items up or down.

Stockmaster LiftTruk is ideally suited for use in Retail Stores and Warehouses for picking of single items and is manufactured from high quality materials; with reasonable care it will provide many years of service.

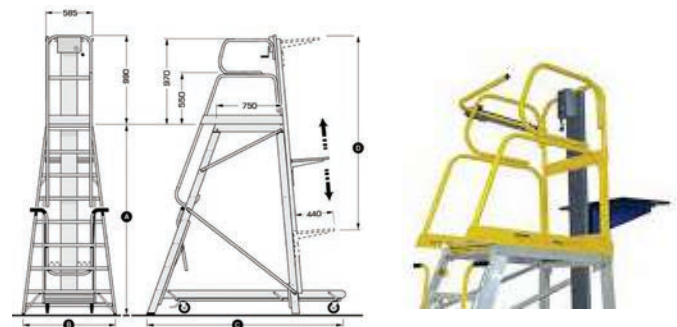

Code	Platform Height mm	A mm	B mm	C mm	D mm
CU SM-LT04	1145	1145	755	1885	1510
CU SM-LT05	1435	1435	795	2015	1795
CU SM-LT06	1720	1720	835	2145	2085
CU SM-LT07	2005	2005	875	2275	2370
CU SM-LT08	2295	2295	915	2285	2655
CU SM-LT09	2580	2580	955	2415	2945
CU SM-LT10	2865	2865	995	2545	3230
CU SM-LT11	3155	3155	1035	2675	3515
CU SM-LT12	3440	3440	1075	2805	3805
CU SM-LT13	3725	3725	1115	2935	4090
CU SM-LT14	4015	4015	1155	3105	4375

### Ladder - Stockmaster Mezzalad

Mezzalad provides convenient, safe, easy access to mezzanine areas and features a space saving mechanism which allows it to be stored flat against the wall when not in use. Mezzalad is brought to the operative position with a simple lift and pull action.

At 600mm, the step width accommodates comfortable access, and two hand rails are provided for safe and easy climbing. The side rails are lengthened to provide hand railing extending 900mm beyond the upper floor, enabling safe step through access to the upper floor while maintaining a hand hold.

The ladder is fastened at the upper floor level. Installation is simple with two universal brackets allowing fastening to be made either to the floor or wall and the ladder may be secured with bolts or screws.

The VH series Mezzalad automatically adjusts to any floor height between the given minimum and maximum service height and suits the majority of applications. For other applications the custom manufactured CM series is available.



- ✓ Fast, safe and easy access to space you've already paid for!
- ✓ Provides access to Mezzanines, Lofts and Loading Docks and other elevated work areas
- ✓ Stores out of the way when not in use with a simple lift and push action
- ✓ Includes an upper floor gate and two hand rails to assist safe and easy climbing
- ✓ May be moved to different locations
- ✓ Is fast and easy to install with just two universal fixing brackets

Code	Service Height		Code	Service Height	
	Min mm	Max mm		Min mm	Max mm
CU SMVH01	2330	2529	CU SMVH03	2744	2977
CU SMVH02	2529	2744	CU SMVH04	2977	3225

Code	Service Height		Code	Service Height	
	Min mm	Max mm		Min mm	Max mm
CU SM-CM100	1310	1420	CU SM-CM111	3225	3385
CU SM-CM101	1420	1545	CU SM-CM112	3385	3675
CU SM-CM102	1545	1675	CU SM-CM113	3675	3990
CU SM-CM103	1675	1820	CU SM-CM114	3990	4280
CU SM-CM104	1820	1975	CM Series Non stock item – made to order NB. Made to order items are non returnable.		
CU SM-CM105	1975	2145			
CU SM-CM106	2145	2330			

### Stockmaster Rota-Gate

Stockmaster Rota-Gate is a side opening platform gate that provides easy access for stock-picking, manufacturing, maintenance and many other tasks. To open or close the gate it is rotated into position which allows the ladder platform to be placed next to the work-face providing a clear open space to get to the task.



**Please note:** When an StockMaster Auto-Gate is fitted, a StockMaster Rota-Gate may be fitted to one side only.

Code	Description
SM-ROTAGATE	Can be fitted to all models of Stockmaster Navigator, StockMaster Tracker and StockMaster Lift-Truk that have been manufactured later than 2008.

### Stockmaster Auto-Gate

Stockmaster Auto-Gate is a platform gate that provides automatic protection against the risk of a fall from the front of a StockMaster ladder platform. As a person enters the platform area the platform gate is automatically urged to the closed position. Release of the locking latch allows exit from the platform and automatically re-sets the gate to the open position.



Code	Description
CU SM-AUTOGATE	Can be fitted to all models of Stockmaster Navigator, StockMaster Tracker and StockMaster Lift-Truk that have been manufactured later than 2008.

### Stockmaster Mezzalift

StockMaster Mezzalift is a cost effective solution for vertical transport of goods to mezzanine floors.

Using a simple winding mechanism, items weighing up to 60kg are easily moved by a single operator.

Featuring a reliable manually operated winch, braking of the load is automatic when the winch handle is released.

The overall length is adjustable to ensure correct operating height at the upper floor level and place the lift table at waist height for easy loading and unloading.

Mezzalift is fast and simple to install with fixing required a just two locations and is provided with a high visibility ground level safety rail system to eliminate the possibility of standing under the lift table.



Code	Service Height Range	
	From mm	To mm
CU SM-MH08	2250	2555
CU SM-MH09	2535	2840
CU SM-MH10	2820	3135
CU SM-MH11	3110	3415
CU SM-MH12	3395	3700
CU SM-MH13	3685	3990
CU SM-MH14	3970	4275

# MONSTAR LADDER

Designed for easy, efficient use in warehousing and workplace environments.

Monstar Order Picking Ladders provide safe and secure access to all your elevated stock. All Ladders feature a huge 585mm x 730mm work platform, retractable safety castors and a 150kg Rated Capacity, reinforced with a strong welded construction. The Monstar Order Picker is guaranteed to make stock picking safer and more efficient for your business.

- ALUMINIUM
- 150KG HEAVY- DUTY
- LIGHTWEIGHT



**i Load Capacity 150kg**

## Order Picking Ladders - Monstar Ladder - 150KG

- ✓ Made to AS/NZS 1892.1.
- ✓ Spring Loaded Castors.
- ✓ Safety Gate for Security and Stability at Elevated Heights.
- ✓ Designed for use on Commercial Sites and Warehouses.
- ✓ Light, Strong, Aluminium Construction with Ribbed Tread.
- ✓ Fully Welded Construction.
- ✓ Lightweight, Manoeuvrable & easy to use.

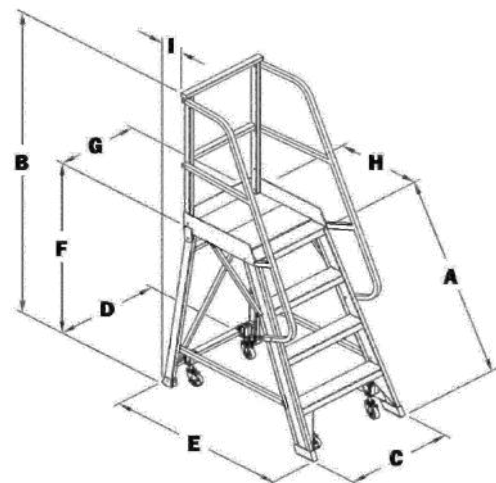

Model	Steps	A mm	B mm	Footprint C x E mm	D mm	F mm	G mm	H mm	I mm
TS MONOP2	2	620	1466	675 x 1025	659	565	585	730	17
TS MONOP3	3	927	1742	715 x 1167	695	840	585	730	37
TS MONOP4	4	1222	2017	758 x 1305	735	1115	585	730	60
TS MONOP5	5	1524	2290	800 x 1460	775	1390	585	730	87
TS MONOP6	6	1812	2570	844 x 1595	815	1665	585	730	112

LADDER HEIGHT ACCESS

# MONSTAR LADDER

**Strong, Lightweight Platform Ladder designed for Heavy Duty Industrial use.**

A range of Platform Ladders designed and manufactured to meet the highest demanding applications in Australia. These ladders are built with industry rated material for moderate to high level use.

- ALUMINIUM
- 150KG HEAVY- DUTY
- LIGHTWEIGHT



**i Load Capacity 150kg**

## Platform Ladders - Monstar Ladder - 150KG

- ✓ Fully Welded Construction.
- ✓ Checkerplate Platform.
- ✓ Wide Base with Rubber Feet.
- ✓ 700mm x 400mm Platform
- ✓ Exceeds AS/NZS 1892.1.
- ✓ Standard Work Platform.
- ✓ Fully Welded Retractable Castors.
- ✓ Optional Handrails Available.



Large Platform



Castor Wheels



Safety Bar

Model	Platform Height mm	Steps
TS MONSTAR2	570	2
TS MONSTAR3	850	3
TS MONSTAR4	1130	4
TS MONSTAR5	1410	5
TS MONSTAR6	1690	6

TS HR - OPTIONAL HAND RAIL



Safety Gate



Folded Ladder

# MONSTAR LADDER

**Compact Step Ladder designed for safe, easy and efficient use for a wide range of applications.**

## Compact Step Ladders - Monstar Ladder - 150KG

A range of Compact Step Ladders designed and manufactured to meet the highest demanding applications in Australia. These ladders are built with industry rated material for moderate to high level use.

- ✓ 150kg Load Rating.
- ✓ Lightweight, Manoeuvrable and easy to use.
- ✓ Rear Roller Castors for ease of movement.
- ✓ Heavy Duty Tread for added safety on all steps.
- ✓ Strong Safety Bracket including recess for storing Tools and Bucket Hooks.
- ✓ Light, Strong, Aluminium Construction.



- ALUMINIUM
- 150KG HEAVY- DUTY
- LIGHTWEIGHT



**i Load Capacity 150kg**

Model	Steps	Top Step Height mm	Safety Bracket Height mm	Footprint Size mm	Packed Size mm	Weight kg
TS MONLM2	2	480	480	620 x 530	900 x 550 x 150	6
TS MONLM3	3	680	480	900 x 550	1200 x 580 x 150	8
TS MONLM4	4	910	480	1180 x 550	1500 x 580 x 150	9

LADDER HEIGHT ACCESS

### StepLadder - Job Station - Fibreglass

The Bailey P170 is more than just a platform stepladder, the P170 is a mobile job station with a massive 610mm x 460mm platform, huge 170kg load rating, carry handle and a range of features aimed at improving safety and productivity.



- ✓ Huge platform area (610 x 457mm) adds comfort and stability
- ✓ New 'trapezoidal tread design' provides an incredibly strong tread to stile joint
- ✓ Multi-function handrail with optional 'DropLok' accessories converts a handrail into a Job Station (15kg capacity)
- ✓ Fully reinforced polypropylene platform with metal inserts for maximum strength
- ✓ Electro - Safe™ (non-conductive)
- ✓ Checker plate 'deck pattern' provides an anti-slip standing area
- ✓ Extra strong, heavy duty fibreglass construction for superior durability
- ✓ Large anti-slip feet for maximum stability and durability
- ✓ Convenient carry handle allows for easy transport for improved mobility and improved productivity
- ✓ Fully integrated bracing and castor system - patented industry leading design
- ✓ Made to AS/NZS 1892.3

Code	Steps	Platform Height mm	Reach Height mm	Weight kg
BA FS13530	3	900	2900	17.9
BA FS13531	4	1200	3200	19.6
BA FS13532	5	1500	3500	21.2
BA FS13533	6	1800	3800	23.4
BA FS13534	7	2030	4030	29
BA FS13535	8	2320	4320	30.3
BA FS13536	10	2910	4910	35.3
BA FS13537	12	3490	5490	40.1
BA FS13648	Optional Safety Gate			

### StepLadder - Job Station - Aluminium

The Bailey P170 is more than just a platform stepladder, the P170 is a mobile job station with a massive 610mm x 460mm platform and a huge 170kg loading rating.

A great platform stepladder for heavy duty industrial trade/commercial use by professional contractors, tradespersons, workplaces and serious DIY/handyman. Made to the requirements of the Australian and New Zealand Standards AS/NZS1892



Safety Gate BA FS13648



5 Step BA FS13540

- ✓ Huge platform area (610 x 460mm) adds comfort and stability
- ✓ New 'trapezoidal tread design' provides an incredibly strong tread to stile joint
- ✓ Multi-function handrail with optional 'DropLok' accessories converts a handrail into a Job Station (15kg capacity)
- ✓ Fully reinforced polypropylene platform with metal inserts for maximum strength
- ✓ Diamond plate 'deck pattern' provides an anti-slip standing area
- ✓ Extra strong, heavy duty aluminium construction for superior durability
- ✓ Large anti-slip feet for maximum stability and durability
- ✓ Convenient carry handle allows for easy transport from job to job
- ✓ Swivel castors for improved mobility and improved productivity
- ✓ Fully integrated bracing and castor system - industry leading design
- ✓ Made to AS/NZS1892.1-1

Code	Steps	Platform Height mm	Reach Height mm	Weight kg
BA FS13538	3	900	2870	16.9
BA FS13539	4	1200	3160	18.4
BA FS13540	5	1500	3450	19.9
BA FS13541	6	1800	3740	21.9
BA FS13542	7	2030	4030	27.4
BA FS13543	8	2320	4320	28.5
BA FS13544	10	2910	4910	33.2
BA FS13545	12	3490	5490	37.6
BA FS13648	Optional Safety Gate			



## Step Ladder - Double Sided - 150KG - Bailey

An ideal "industrial duty" rated ladder for factory, office, warehouse, builders and painters. Double sided for greater versatility and greater load bearing strength this ladder is made to Australian and New Zealand Standard AS/NZS1892.1 and has a load rating of 150kg.



BA FS13385

BA FS13386

Code	Steps	Platform Height mm	Reach Height mm	Weight kg
BA FS13385	3	900	2300	4.9
BA FS13386	4	1200	2600	6.1
BA FS13387	5	1500	2900	7.7
BA FS13388	6	1800	3200	9.2

## Step Ladder - Multi-purpose

Ideal for the tradesperson or serious DIY requiring the benefits of one of the most versatile ladders on the market.

Converts into four different configurations, a double sided step ladder, a single straight ladder, two individual trestles and a telescopic adjustable ladder.

- ✓ Industrial Duty Rated. Designed for use on industrial work sites
- ✓ 135kg load rating
- ✓ Strong, aluminium construction
- ✓ The most versatile ladder you can own
- ✓ Telescopic design quickly adjusts to a comfortable working height
- ✓ Adjust height quickly with spring loaded 'J' locks
- ✓ Adjust angle positions easily with push knobs
- ✓ Wide flared bottom for firm support and stability
- ✓ Anti-slip feet for added safety and stability



Step ladder

Code	Ladder Height mm	Reach Height mm	Weight kg
BA FS13644	2300 / 4500	3100 / 5500	16.7

## Order Picker - Temporary Work Platform

The Bailey Order Picker Ladders are designed for safe, easy and efficient use around the warehouse or workplace.

Incorporating a large, stable work platform (500mm x 510mm) and a strong welded frame construction. The Bailey Order Picker makes stock picking a breeze.



BA FS10864

Shown with optional safety gate

Code	Steps	Platform Height mm	Reach Height mm	Weight kg
BA FS10863	3	830	2800	17.5
BA FS10864	4	1111	3100	19.5
BA FS10865	5	1390	3400	22.5
BA FS10866	6	1670	3700	23.5
BA FS10867	7	1950	3900	28.5
BA FS10868	8	2220	4200	30.5
BA FS22995	Safety Gate			

## Ladder - Deluxe Order Picker - Walk Thru

Bailey Ladderweld "2 in 1" Access Platform Ladders are designed for safe, easy and efficient use in warehousing, vehicle maintenance, mining, aviation and heavy industry workplaces.

This Access Platform's dual design ability to be used as an Order Picker or 'Walk-thru' is perfect for stock picking and access to mezzanine floors, vehicle access and warehousing (no need to stock several products)

\*\* Supplied as a 'flat pack' for optimal transporting.



BA FS13592

Code	Steps	Platform Height mm	Reach Height mm	Weight kg
BA FS13591	3	828	2800	38.1
BA FS13592	4	1104	3100	40.65
BA FS13593	5	1381	3400	43.0
BA FS13594	6	1656	3700	46.0
BA FS13595	7	1933	3900	48.5
BA FS13596	8	2209	4200	51.0
BA FS13597	10	2761	4800	62.0
BA FS13598	12	3313	5300	69.0
BA FS13599	14	3866	5900	76.4

## Platform Ladder - Aluminium - Single Sided - 120KG - Bailey

This ladder is ideal for use in a office or retail environment to access stock at the back of house, merchandising front of house or general access to cupboards and stationery.

- ✓ 120kg load rating and industrial duty rating.
- ✓ Large 300 mm deep and 350 mm wide platform provides a comfortable work position.
- ✓ Multi function flip top handrail.
- ✓ Anti-slip PVC boots for added stability.
- ✓ Trapezoidal tread profile for strength and durability.
- ✓ 115 mm deep slim profile when closed makes it easy to store when not in use.



Code	Steps	Open Size L x W x H mm	Close Size L x W x H mm	Reach Height m	Platform Height mm	Weight kg
BA FS13868	2	666 x 500 x 1170	1277 x 115 x 500	2.6	570	4.55
BA FS13869	3	843 x 540 x 1586	1719 x 115 x 540	2.9	852	5.62
BA FS13870	4	1020 x 567 x 1866	2018 x 115 x 567	3.1	1132	6.9

## Industrial Aluminium Slimline Platform Ladder - 120KG - INDALEX



Code	Steps	Overall Height mm	Platform Height mm	Weight kg
TS TRDP5/2	2	1520	600	5.6
TS TRDP6/3	3	1830	900	6.9
TS TRDP7/4	4	2130	1200	8.3
TS TRDP8/5	5	2130	1500	11

## Step Ladder - Safety Gate - Bailey

The Safety Gate is designed to be fitted to Bailey Aluminium and Fibreglass Industrial Platform stepladders fitted with plastic handrails. When fitted, this product will improve the safety for the user by providing a fully enclosed work area, whilst working at heights.

- ✓ Fully surrounds the user
- ✓ 3 Improves safety on platform stepladders
- ✓ 3 Maintains a safe working zone
- ✓ 3 Folds down for easy access
- ✓ 3 Folds away with ladder
- ✓ 3 Quick and easy to fit
- ✓ 3 Simple to use
- ✓ 3 Ladder still fits on roof racks



Code	Ladder Height mm	Reach Height mm	Weight kg
BA FS13648	Safety Gate for Baily Job Station platform ladder		2.5

## Industrial Aluminium Slimline Platform Ladder - 150KG - INDALEX



Code	Steps	Platform Height mm	Weight kg
TS PROP5/2	2	600	11.0
TS PROP6/3	3	900	12.0
TS PROP7/4	4	1200	13.0
TS PROP8/5	5	1500	14.0
TS PROP9/6	6	1800	16.0
TS PROP10/7	7	2100	20.0
TS PROP11/8	8	2400	22.0
TS PROP12/9	9	2700	24.0
TS PROP13/10	10	3000	26.0
TS PROP15/12	12	3600	30.0

## Aluminium Double Sided Step Ladder - 120KG - 135KG - 150KG - 180KG - INDALEX

- ✓ 3 Year Warranty for Tradesman.
- ✓ Lifetime warranty for Pro Series.
- ✓ Double solid Aluminium Rivet Constructions to the joints allows for repeated use without loosening up over time.



Code	Steps	Ladder Size mm	Weight kg
TS TRDS2D - 150kg	2	600	3.0
TS TRDS3D - 150kg	3	900	4.1
TS TRDS4D - 150kg	4	1200	4.9
TS TRDS5D - 135kg	5	1500	6.5
TS TRDS6D - 135kg	6	1800	7.4
TS TRDS7D - 120kg	7	2100	9.2
TS TRDS8D - 120kg	8	2400	10.0
TS PROS9D - 180kg	9	2700	14.0
TS PROS10D - 180kg	10	3000	16.0
TS PROS12D - 150kg	12	3600	20.0
TS PROS14D - 150kg	14	4300	25.0
TS PROS16D - 150kg	16	4800	30.0

## Pro Series Industrial Fibreglass Platform Ladder - 150KG - INDALEX

- ✓ Platform Work Area - 660mm x 400mm.
- ✓ Solid 900mm High Guard Rail.
- ✓ Available - Wheel Kits, Locking Gates, Hand Rails, Tool Tray and Heavy Duty Top Shelf.



Heavy Duty Top Shelf

Wheel Kit



Side Handrails



PROPF74

Code	Steps	Platform Height mm	Weight kg
TS PROPF5/2	2	600	13.0
TS PROPF6/3	3	900	14.0
TS PROPF7/4	4	1200	16.0
TS PROPF8/5	5	1500	17.0
TS PROPF9/6	6	1800	20.0
TS PROPF10/7	7	2100	24.0
TS PROPF11/8	8	2400	26.0
TS PROPF12/9	9	2700	28.0
TS PROPF13/10	10	3000	30.0
TS PROPF15/12	12	3600	36.0

## Aluminium Dual Purpose Ladder - 150KG - INDALEX

- ✓ Pro Series Lifetime Warranty.
- ✓ Double solid Aluminium Rivet Constructions to the joints allows for repeated use without loosening up over time.



PRODP6

Code	Steps	Ladder Size m	Weight kg
TS PRODP6	6	1.8/3.2	8.8
TS PRODP7	7	2.1/3.8	10.0
TS PRODP8	8	2.4/4.4	12.0

## Fibreglass Double Sided Ladder - 150KG - 180KG - INDALEX

- ✓ Double solid Aluminium Rivet Constructions to the joints allows for repeated use without loosening up over time.
- ✓ Robust Fibreglass Side Rails utilising UV Inhibitors for greater durability.
- ✓ 5 Years Warranty.
- ✓ Heavy Duty Fixed Feet for 8ft - 16ft.



Code	Steps	Ladder Size mm	Weight kg
TS PROSF3D - 180kg	3	900 (3')	5.8
TS PROSF4D - 180kg	4	1200 (4')	7.4
TS PROSF5D - 180kg	5	1500 (5')	9.2
TS PROSF6D - 180kg	6	1800 (6')	11.0
TS PROSF7D - 180kg	7	2100 (7')	13.0
TS PROSF8D - 180kg	8	2400 (8')	15.0
TS PROSF10D - 180kg	10	3000 (10')	21.0
TS PROSF12D - 150kg	12	3700 (12')	26.0
TS PROSF14D - 150kg	14	4300 (14')	30.0
TS PROSF16D - 150kg	16	4800 (16')	36.0

### Step Stool - 'Step Safe' - 200KG

This safety step ensures you can safely reach for high places - it's a proven performer in hard traffic areas such as Supermarkets, Libraries, Factories and Offices. The wide base platform together with the no-slip steps means your foot stays where you put it. Anti-skid pads are fitted for extra slippery floor surfaces.

- ✓ Anti-skid rubber pads.
- ✓ 500x500x360mm.
- ✓ Colour: Orange.
- ✓ Industrial rated.



Code	Base mm	Height mm	Capacity kg
NY E1513A	500 x 500	360	200

### Step Stool - Jumbo - Mobile - 180KG

The JUMBO TEAMSTEP Step Stool has been designed to allow the user to reach higher places easily and safely.

The wide base platform and large contrasting anti slip contact surfaces of the JUMBO TEAMSTEP Stool Safety Step Stool ensure your foot stays where you put it.

Anti skid rubbers are great for extra slippery surfaces and castors make your day easy on carpet or concrete.

- ✓ Sturdy yet lightweight construction.
- ✓ Totally mobile.
- ✓ Castors are spring-loaded to retract when in use.
- ✓ Fitted with non-slip tape.



Code	Size mm	Height mm	Weight kg
TS TSJUMBO	375	370	5.0

### Step Stool - 'STEP UP' - 260KG

With a 180 kilogram capacity, the Team STEP UP Step Stool is the strongest and safest Step Stool on the market. Featuring a large deck size of 370mm x 370mm and four way access the Secure Step Safety Step Stool is ideal for supermarkets, libraries, factories and offices.

- ✓ Strengthened under supports to give full stability without the top bowing.
- ✓ The unit will not bend or sag.
- ✓ Large Deck size 370 x 370mm.
- ✓ Fully fitted with non-slip tape.
- ✓ Four-way access.
- ✓ Fitted with Non-Slip rubber feet.
- ✓ 260kg Load Rated.
- ✓ Linear Low Density Polyethylene.



TS TSSU-YEL



TS TSSU-ORA

Code	Base mm	Height mm	Weight kg
TS TSSU-ORA	370 x 370	370	5.0
TS TSSU-YEL	370 x 370	370	5.0

### Step Stool - Mobile - 180KG

With a 180 kilogram capacity, the Step Stool Mobiles are the strongest and safest Step Stool Mobiles on the market. Step Stool Mobile is ideal for supermarkets, libraries, factories and offices.

- ✓ Totally Mobile.
- ✓ Anti-Slip Surface.
- ✓ Lightweight, Durable One Piece Construction.
- ✓ Stackable.
- ✓ No rusting or dangerous sharp edges.
- ✓ Castors are spring loaded to retract when TEAMSTEP is in use.
- ✓ Fitted with Non-Slip Tape.
- ✓ Made of Remoulded Plastic.



TS TSTSYEL



TS TSTSBLU

Code	Size mm	Height mm	Weight kg
TS TSTSBLU	315	395	4.2
TS TSTSYEL	315	395	4.2

# MONSTAR STEP

LADDER HEIGHT ACCESS

**Outperforms other similar safety steps in longevity and strength.**

## Step Stool - Monstar Step - 260KG

The all new MONSTAR STEP<sup>®</sup> is the only plastic safety step that has superior design features over existing injection moulded safety steps available in Australia. The Monstar Step is a quality, cost effective solution designed for intermittent use. Designed to be durable, safe and robust.

MONSTAR STEP<sup>®</sup> has a large, safer area of non slip tape including an indentation in the lower step so the tape will not wear away - ensuring longevity of non slip surface.

- ✓ Large Deck Size - 370mm x 370mm.
- ✓ Fully Fitted with Non-Slip Tape.
- ✓ Four Way Access.
- ✓ Rubber Feet.



**i Load Capacity 260kg**



Non-slip Tape



Four Way Access



Built in Rubber Feet

Model	Size mm	Height mm	Weight kg	Capacity kg
MONSTEP	370 x 370	375	3.5	260

# These Reflexequip Work Platforms are the only safe and authority approved way of lifting personnel to a height when using a forklift.

LADDER HEIGHT ACCESS

## TS TSWP - Work Platform

- ✓ Manufactured to meet Australian Standards - AS-2359.1.
- ✓ Designed to carry 2 people & up to 250kg.
- ✓ 1200 x 1200 x 1000mm with 2200mm Safety Screen.
- ✓ Toe Boards on all sides.
- ✓ Skid Resistant Floor Plates.
- ✓ Inward Opening Self Closing Door.
- ✓ Internal Hand Rail.
- ✓ Full Length Fork Sleeves.
- ✓ Safety Chains Fitted.
- ✓ 40mm Square Tube Construction.
- ✓ Pins supplied for attaching to fork.
- ✓ Two Harness Anchor Points.
- ✓ Precision made Quality Construction.
- ✓ Australian Made.

**APPROVED PERSONNEL PLATFORM**



## TS BH01151 - Safety Harness

- ✓ Energy Absorbing 2.0m Lanyard.
- ✓ Particularly suited to the hire industry.
- ✓ Fall/Arrest 136kg.
- ✓ Only available for use on fully welded work platform as per the TSWP pictured here.
- ✓ NOTE: The use of a safety harness is not mandatory with this platform.



## TS TSWPF - Collapsible/Folding Work Platform

- ✓ 250kg Rating
- ✓ Stores & assembles with ease.
- ✓ Ideal for freighting.
- ✓ Complies with Australian Safety Standards - AS-2359-1.
- ✓ Comes ready to use.

**FOLDS AWAY 5 IN MINUTES!**



Model	Width mm	Length mm	Height mm	Weight kg
TS TSWP	1200	1200	1000	120
TS TSWPF	1200	1200	1000	120